

# Specification For Approval

Customer :  
Description : **DC FAN 24V**  
Dimension : **120\*120\*25mm**  
Model No. : **PSAD2A225BH MF00**  
Internal Code :  
Revision : **A**  
Specification No. :  
Customer Approval No. :  
Issue Date :2021-08-31

Sales APPROVED	Customer APPROVED	PLEASE SIGN AND RETURN THIS PAGE TO US FOR FILING AFTER AUTHENTICATION.
DRAWN	CHECKED	APPROVED

# SPECIFICATION

## 1.MECHANICAL CHARACTERISTICS

<b>MOTOR DESIGN</b>	<b>DC brushless 4 poles motor design</b>
<b>BEARING SYSTEM</b>	<b>Ball Bearing System</b>
<b>MATERIAL OF HOUSING</b>	<b>Thermoplastic PBT of UL 94V-0</b>
<b>MATERIAL OF FAN BLADE</b>	<b>Thermoplastic PBT of UL 94V-0</b>
<b>DIRECTION OF ROTATION</b>	<b>Counter-clockwise viewed from front of fan blade</b>
<b>WEIGHT(g)</b>	<b>190</b>

## 2. ELECTRICAL CHARACTERISTICS

<b>RATED VOLTAGE</b>	<b>24 VDC</b>
<b>INPUT CURRENT</b>	<b>0.31 A                      MAX: 0.39 A</b>
<b>INPUT POWER</b>	<b>7.44 W                        MAX: 9.36 W</b>
<b>OPERATING VOLTAGE RANGE</b>	<b>16~27.6 VDC</b>
<b>STARTING VOLTAGE</b>	<b>16 VDC (At 25°C, POWER ON/OFF)</b>
<b>OPERATING TEMPERATURE/ HUMIDITY RANGE</b>	<b>-10°C ~ +70°C / 5% ~ 90 %RH</b>
<b>STORAGE TEMPERATURE/ HUMIDITY RANGE</b>	<b>-40°C ~ +70°C / 5% ~ 95 %RH</b>

## PERFORMANCE CHARACTERISTICS

<b>RATED SPEED(RPM)</b>	<b>4100RPM± 10%</b>	<b>(At 25 °C , After 10 minutes)</b>
<b>DUTY 50% SPEED(RPM)</b>	<b>2100RPM± 10%</b>	
<b>AIR FLOW</b>	<b>126.86 CFM</b>	<b>Min: 115.4 CFM</b>
<b>STATIC PRESSURE</b>	<b>17.62 mmH<sub>2</sub>O</b>	<b>Min: 14.98 mmH<sub>2</sub>O</b>
<b>SOUND PRESSURE NOISE(1m)</b>	<b>51.5 dB(A)</b>	<b>MAX: 53.11 dBA</b>
<b>INSULATION RESISTANCE PLASTIC FRAME</b>	<b>Min. 10MΩ at 500VDC between frame and (+) terminal.</b>	
<b>DIELECTRIC STRENGTH</b>	<b>5mA max. at 500VAC 60Hz 1 minute between frame and (+) terminal.</b>	
<b>LIFE EXPECTANCY</b>	<b>70,000Hours, at 40°C, 15%~65%RH</b>	
<b>PROTECTION</b>	<b>Automatic Restart</b>	
	<b>Polarity Protection</b>	
<b>RoHS-Free Pb</b>	<b>RoHS compliance</b>	
<b>IP Protection Grade</b>	<b>No IP Protection</b>	

## SAFETY APPROVAL

<b>SAFETY</b>	<b>UL &amp; CUL</b>	<b>TUV</b>
<b>NO.</b>	<b>E181279</b>	<b>82897</b>

# PERFORMANCE CURVES

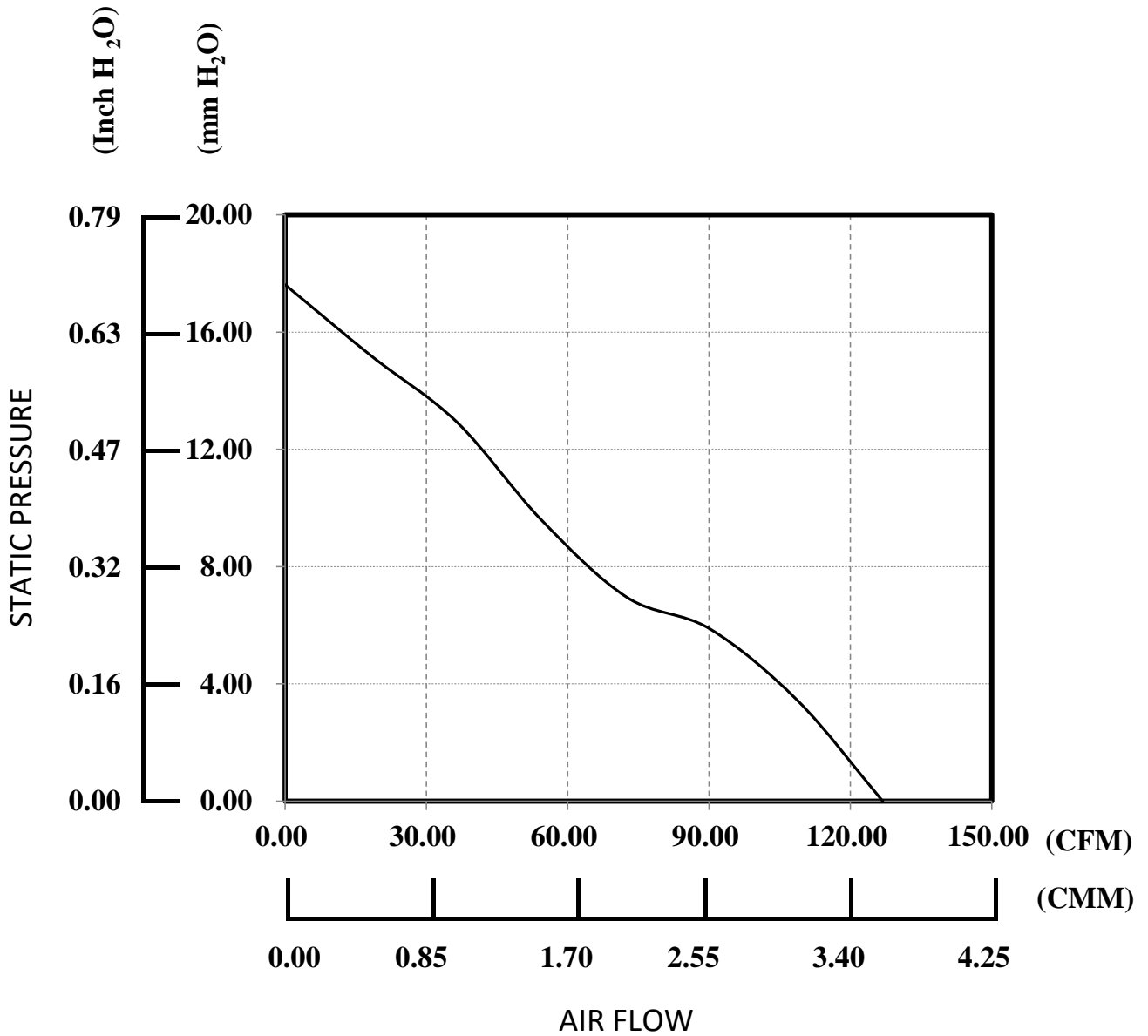

TEST CONDITION:

INPUT VOLTAGE ----- OPERATION VOLTAGE  
 TEMPERATURE ----- ROOM TEMPERATURE  
 HUMIDITY ----- 65%RH

# DIMENSION

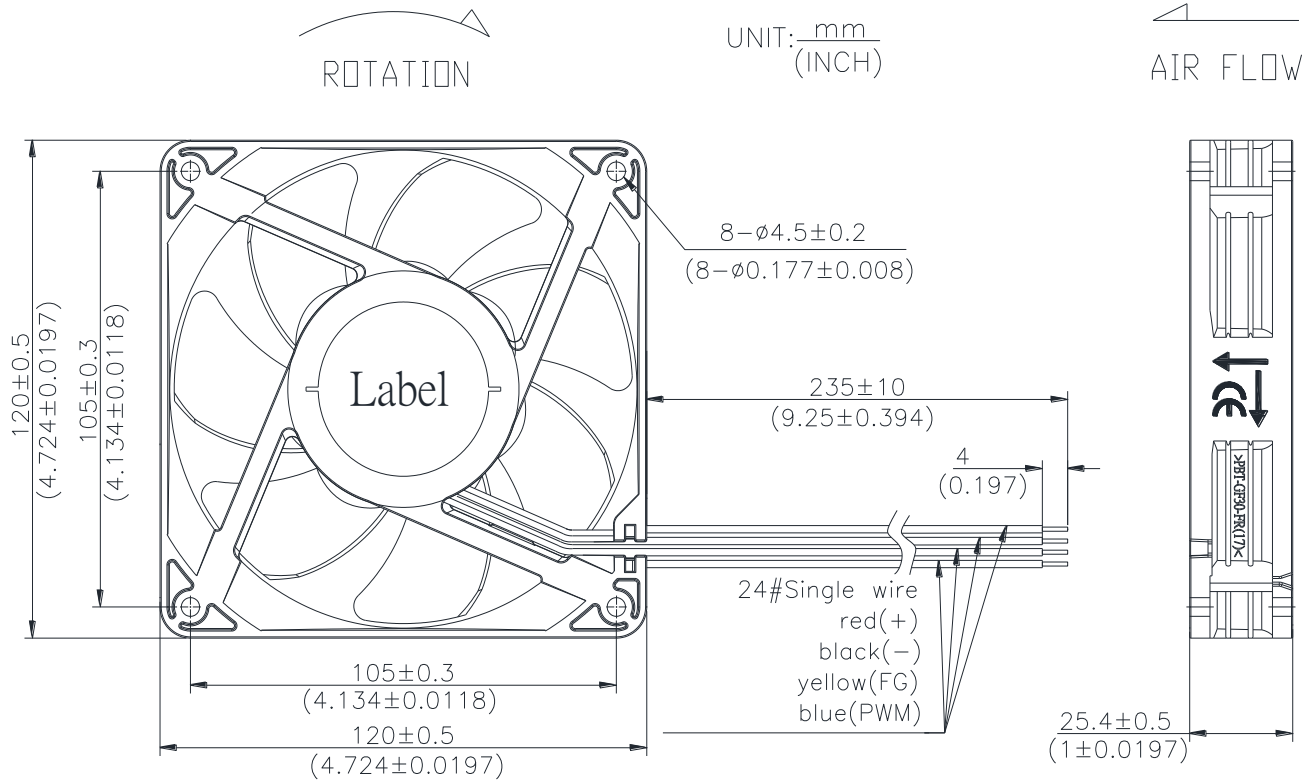

# LABEL



## Date Code

1	35	2
last number of the year, e.g.: 1 stands for 2011, 2 stands for 2012 ... 9 stands for 2019 0 stands for 2020	week, e.g.: 35 stands for 35 week	the day of one week, e.g.: 1 stands for Monday, 2 stands for Tuesday, 6 stands for Saturday, 7 stands for Sunday.

## Descriptions

- 1 AVID will not guarantee the performance of the products if the application condition falls outside the parameters set forth in the specification.
- 2 A written request should be submitted to AVID prior to approval if abnormality and deviation from this specification is required.
- 3 Please exercise caution when handling fans. Damage may be caused when pressure is applied to the impeller, or if the fans are handled by the lead wires, or if the fans are hard -dropped onto the production floor.

DON'T TOUCH !

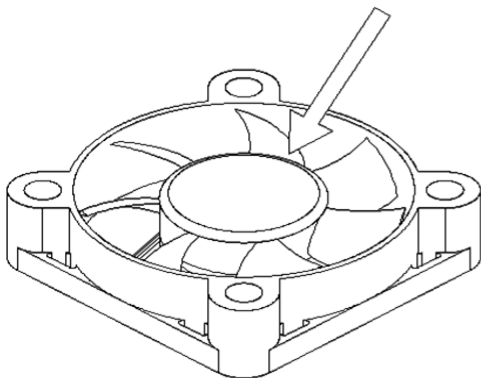

DON'T PUSH !

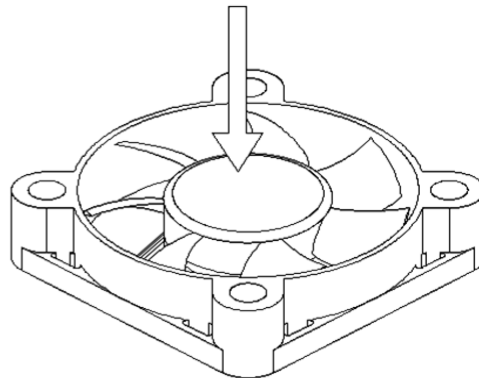

- 4 The correct polarity, Positive(+) and Negative(-), has to be clearly identified before connecting the fan to the power. Beware of the right connection as reversed polarity may cause damage since no effective protection can be introduced against such errors.
- 5 Except as pertains to some special designs, any failure and problems regarding safety of the product caused by the introduction of powder, droplets of water or encroachment of insert in the hub are not guaranteed.
- 6 AVID fans are not suitable where any corrosive fluids are introduced to their environment.
- 7 Not all fans are provided with the Lock Rotor Protection feature. If you impair the rotation of the impeller for the fans that do not have this function, the performance of those fans will lead to failure.
- 8 It is important to consider safety when testing the fans. A suitable fan guard should be fitted to the fan guard against any potential for personal injury.
- 9 Please be cautious when mounting the fan. Incorrect mounting of fans may cause excess resonance, vibration and subsequent noise.
- 10 Please ensure all fans are stored according to the storage temperature limits specified. Do not store fans in a high humidity environment. We highly recommend performance testing is conducted before shipping, if the fans have been stored over 6 months.

## Statement on RoHS Compliance

We guarantee that all the products including the parts , packaging materials conform to the Directives of RoHS (2015/863/EU)

No	Name of hazardous substance	Threshold value(ppm, mg/kg)
1	Cadmium and cadmium compounds(Cd)	100
2	Lead and lead compounds(Pb)	1000
3	Mercury and mercury compounds(Hg)	1000
4	Hexavalent chromium compounds(Cr6+)	1000
5	Polybrominated Biphenyls (PBB)	1000
6	Polybromodiphenyl ether (PBDE)	1000
7	Diethyl phthalate(DEHP)	1000
8	Butyl benzyl phthalate(BBP)	1000
9	Dibutyl phthalate (DBP)	1000
10	Diisodecyl-o-phthalate (DIDP)	1000

Products groups that exemptions from the Restriction of Hazardous Substances,(RoHS) Directive will following RoHS exceptions

If have other requirements, A new contract will draw up in additional for discuss .

# PWM SPECIFICATION

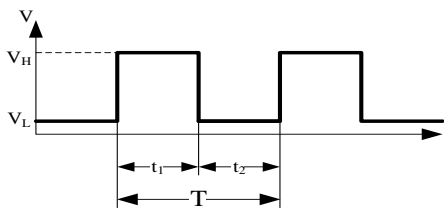

PWM Signal

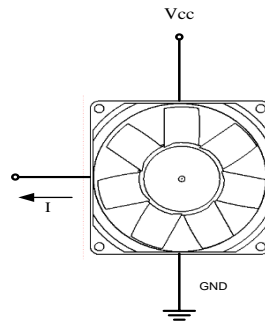

PWM Signal Table

Parameter	Min	Typical	Max	Unit
<i>F<sub>pwm</sub></i>	20K	25K	30K	Hz
<i>V<sub>H</sub></i>	4	5	5	V
<i>V<sub>L</sub></i>	--	--	0.6	V
<i>I</i>	--	6	--	mA
<i>D.C.</i>	0	--	100	%

1. Time Period :  $T = \frac{1}{F_{pwm}} = t_1 + t_2$  (sec)

2. Duty Cycle :  $D.C = \frac{t_1}{t_1 + t_2} \times 100 \%$

★ Electrical Characteristics at  $T_a = 25^\circ\text{C}$

★ Suggest O.C. Circuit

★ **Adjust the duty cycle from 0% up to 100%**

## ■ Tolerance of Duty V.S RPM

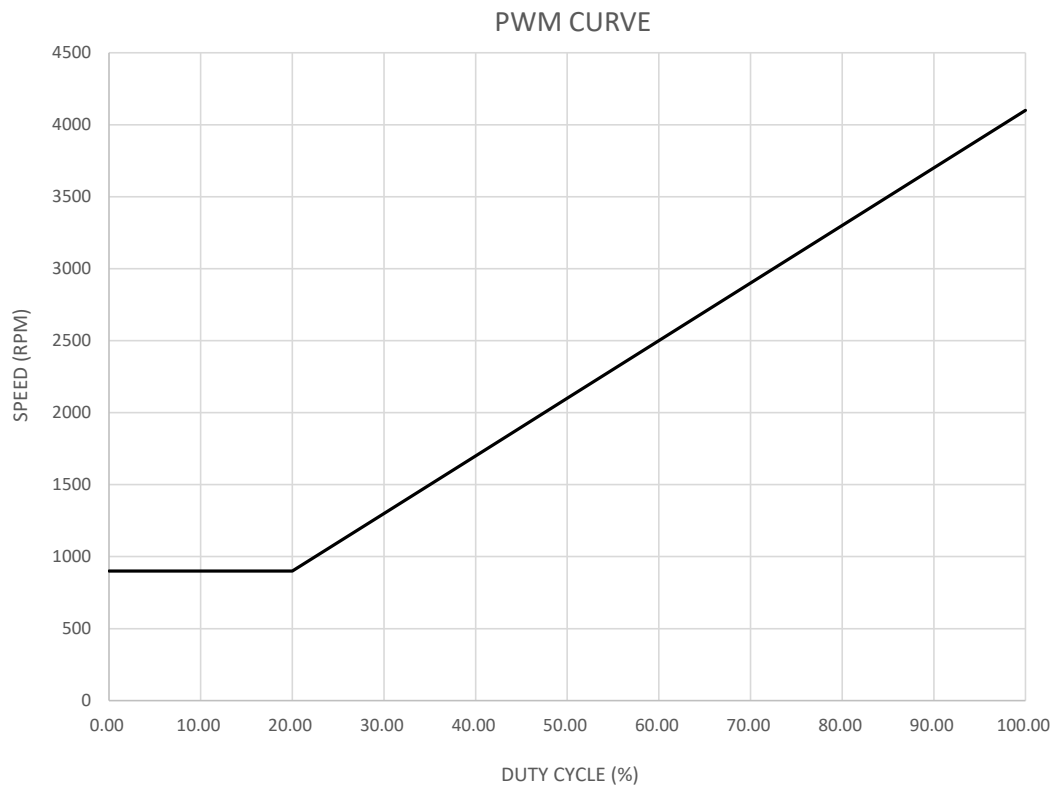

# SENSOR SPECIFICATION

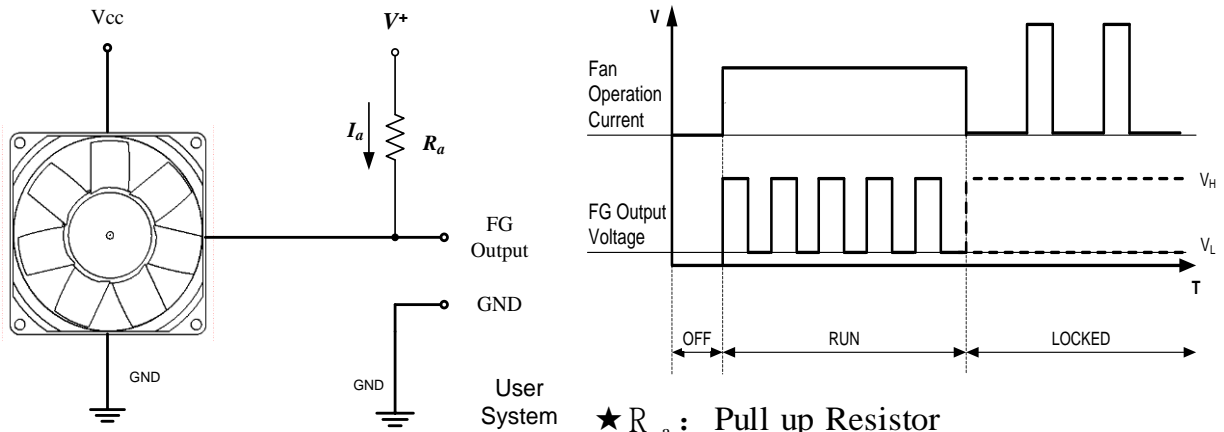

★  $R_a$  : Pull up Resistor

$$\star R_a \geq \frac{V^+}{I_{a(max)}}$$

■ Electrical Characteristics: at  $T_a=25^\circ\text{C}$  ,  $V_{cc}=24\text{V}$

Parameter	Ratings			Unit
	Min	Type	Max	
FG Supply Voltage ( $V^+$ )	--	--	$V_{cc}$	V
FG Output Current ( $I_a$ )	--	--	5	mA
FG Output ( $V_L$ )	--	0.3	0.5	V
FG Output ( $V_H$ )	$2.8^{\star 1}$	--	--	V

★<sup>1</sup> :  $V^+ \geq 3.3\text{V}$

